



**RED POLE
ENERGY**

51V 100Ah GOLF BATTERY DATA SHEET



PRODUCT FEATURES

- Ultra Safe Lithium Iron Phosphate (LiFePO4) Cells
- Integrated Battery Management System (BMS)
- Low Self-Discharge (<3% per month)
- Water and Dust Resistant (IP65)
- Long Life > 3 500 life cycles
- Light Weight - up to 70% lighter
- Compact - up to 50% smaller
- Fast Charging
- Zero Maintenance
- Cost Effective
- Extreme Operating Temperatures
- Includes External Smart LCD Display

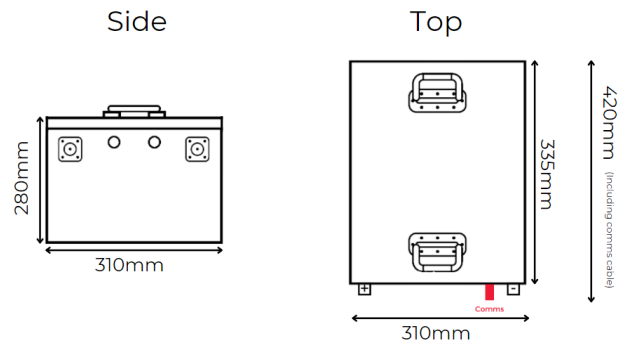

TECHNICAL SPECIFICATION

Model		RP-51V-100AH-GC	
Nominal Voltage	51.2 VDC	Charge Current Recommended	20 A
Usable Capacity	5.12 kWh	Charge Current Quick Charge	50 A
Nominal Capacity	100 Ah	Charge Current Max	100 A
Dimensions (L x W x H) (mm)	335 (420) x 310 x 280	Charge Time Recommended Charge	5 hrs
Weight (kg)	43.2 kg	Charge Time Quick Charge	2 hrs
Terminal Connectors	M8 Terminals	Discharge Current Max Continuous	100 A
Casing Material	Metal	Discharge Current Peak (< 10s)	200 A
IP Rating	IP65	Operating Voltage Range	40 - 58.4 VDC
Operating Temperature Range	Charge: 0°C to 45°C Discharge: -20°C to 60°C	Max Charge Voltage	58.4 VDC
Protection	Over-voltage Under-voltage Short circuit	Self-Discharge Rate	Max 3% per month
Expected Lifespan	10 Year Design Life	Communication Port	CAN, RS485, Bluetooth
Warranty	5 years	Cell Type	LiFePO4 3.2V 105Ah
Humidity Range	< 95% RH	Cell Configuration	16S1P

www.redpoleenergy.co.za | support@redpoleenergy.co.za
021 023 3325