



**RED POLE  
ENERGY**

# 12V 60Ah Automotive Cranking Battery

## DATA SHEET



### PRODUCT FEATURES

- Ultra Safe Lithium Iron Phosphate (LiFePO4) Cells
- High Temperature Casing (PC/ABS with VO rating)
- Automotive Grade Battery Management System (BMS)
- Extreme Operating Temperatures (-20C to 70C)
- Low Self-Discharge (<3% per month)
- Sealed Against Water And Dust (IP66)
- Long Lifespan (6 to 10 Years)
- Zero Maintenance & Cost Effective
- 50% Lighter and Charges faster (Petrol Saving)
- 100% Usable Capacity vs Lead Acid 50% (60Ah = 120Ah)

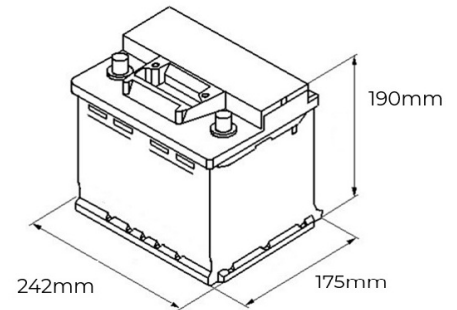

### TECHNICAL SPECIFICATION

Model		RP-12V60Ah-SL	
Nominal Voltage	12.8VDC	CCA	660A
Nominal Capacity	60Ah	Discharge Current   Max Continuous	60A
Dimensions (L x W x H) (mm)	242 x 175 x 190	SCharge Current   Max Continuous	60A
Weight (kg)	5.8 kg	Cell Type	LiFePO4   Cylindrical LFP
Terminal   Connectors	Auto Post Terminal	Operating Voltage Range	10V - 14.6V
Protection	Over Voltage   Low Voltage   Over Current   Over Temperature   Low Temperature   Short Circuit	Self-Discharge Rate	< 3% per month
IP Rating	IP 66	Operating Temperature Range:	Charge: 0°C to 55°C   Discharge: -20°C to 70°C
Casing Material	PC / ABS + VO	Expected Lifespan	6 - 10 years
Alternative To Lead Acid Battery Models:	621, 639, 646, 652, 668	Warranty	3 years

[www.redpoleenergy.co.za](http://www.redpoleenergy.co.za) | [support@redpoleenergy.co.za](mailto:support@redpoleenergy.co.za)  
021 023 3325